

National Formosa University

Mechanical Design Engineering

Computer-Aided Design Internship bg3 Final Report

鋼球運動系統

Marble Machine System

學生：

機械設計工程系二乙 40623203 蔡宜芳

機械設計工程系二乙 40623206 邱妍蓁

機械設計工程系二乙 40623207 呂沛蓉

機械設計工程系二乙 40623244 林俊鎧

機械設計工程系二乙 40623248 廖柏誠

機械設計工程系二乙 40623250 湯峻傑

指導教授：嚴家銘

2019.01.07

Catalog

Catalog	i
Chart Catalog	ii
Chapter 1 Preface	1
1.1 Design Motivation	1
1.2 Design Purpose	1
Chapter 2 Application Software.	2
2.1 Onshape	2
2.2 Inventor	2
2.3 V-rep	4
Chapter 3 Design Introduction	6
3.1 Introduction	6
Chapter 4 Process	7
4.1 Process	7
Chapter 5 Issue & Solution	8
5.1 Design	8
5.2 V-rep	8
5.3 Report	8
Chapter 6 Assignments	15
6.1 Assignments	15
Chapter 7 Conclusion	16
7.1 Conclusion	16
Chapter 8 References	17

Chart Catalog

Figure 2.1	Lift	2
Figure 2.2	Vortex-rotating-disk	3
Figure 2.3	Screw-and-Flywheel	3
Figure 2.4	Assembly	4
Figure 2.5	Simulation	5
Figure 3.1	Simulation	6
Figure 4.1	Process	7
Figure 5.1	Start.bat	9
Figure 5.2	For loop	10
Figure 5.3	Advisor	11
Figure 5.4	transform-mistake	12
Figure 5.5	transform-correct	12
Figure 5.6	modify-chapers	13
Figure 5.7	image	14

Chapter 1 Preface

前言

1.1 Design Motivation

After grouping, among the eight subjects given by the teacher, we discussed and studied each subject. Finally, we selected the topic of the marble machine system. Because the marble machine system is the suitable for our ability, we decided to design the system by ourselves. After the research in many aspect, decided to build a playground for the marble machine system, and watch the bobo always rolling. It's soothing that make everyone calm.

1.2 Design Purpose

The purpose of this topic is to skillfully use Onshape to draw components and V-rep simulations, promote our own strength and apply the system to the future practical applications. For the reason, we search for the related videos on the web and refer to the topic of the senior sister. However, we refer to most of the data to be single. It makes us want to make more mechanism to coordinate with each other and design our own marble machine system.

Chapter 2 Application Software

軟體

2.1 Onshape

Onshape is a computer-aided design (CAD) software system, delivered over the Internet via a Software as a Service (SAAS) model.

Onshape makes extensive use of cloud computing.

Onshape allows teams to collaborate on a single shared design, the same way multiple writers can work together editing a shared document via cloud services.

Onshape upgrades are released directly to the web interface, and the software does not require maintenance work from the user.

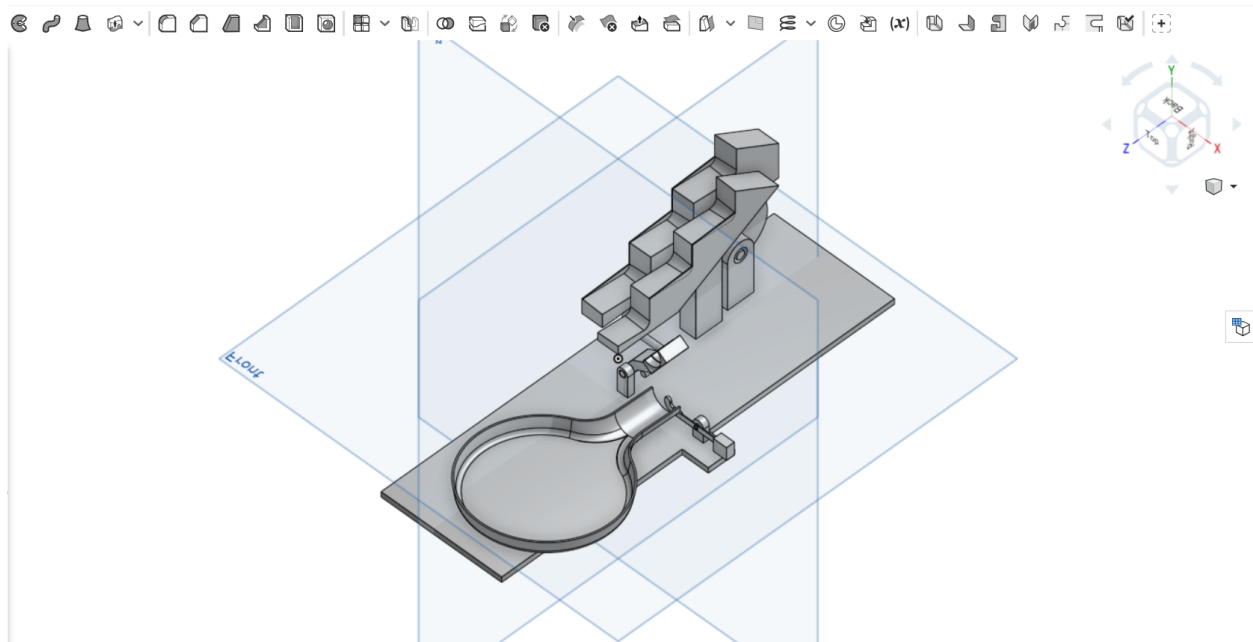

Figure 2.1: Lift

2.2 Inventor

Autodesk Inventor is a computer-aided design application for 3D mechanical design, simulation, visualization, and documentation developed.

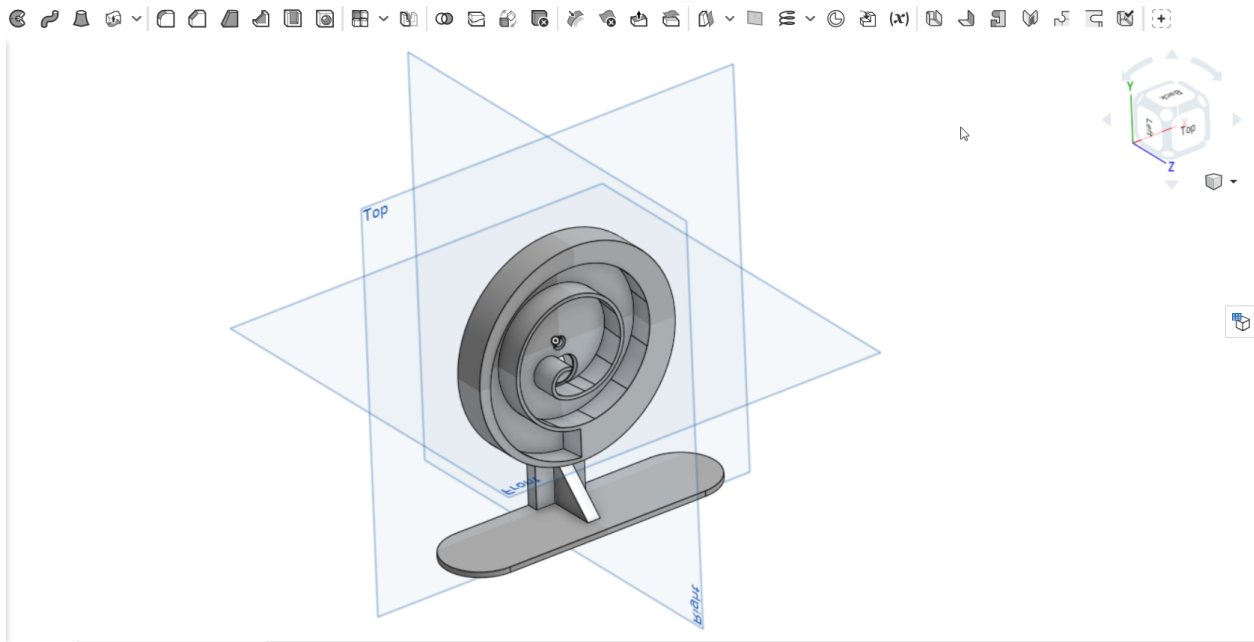

Figure 2.2: Vortex-rotating-disk

Inventor allows 2D and 3D data integration in a single environment, creating a virtual representation of the final product that enables users to validate the form, fit, and function of the product before it is ever built. Autodesk Inventor includes powerful parametric, direct edit and freeform modeling tools as well as multi-CAD translation capabilities and in their standard DWG™ drawings.

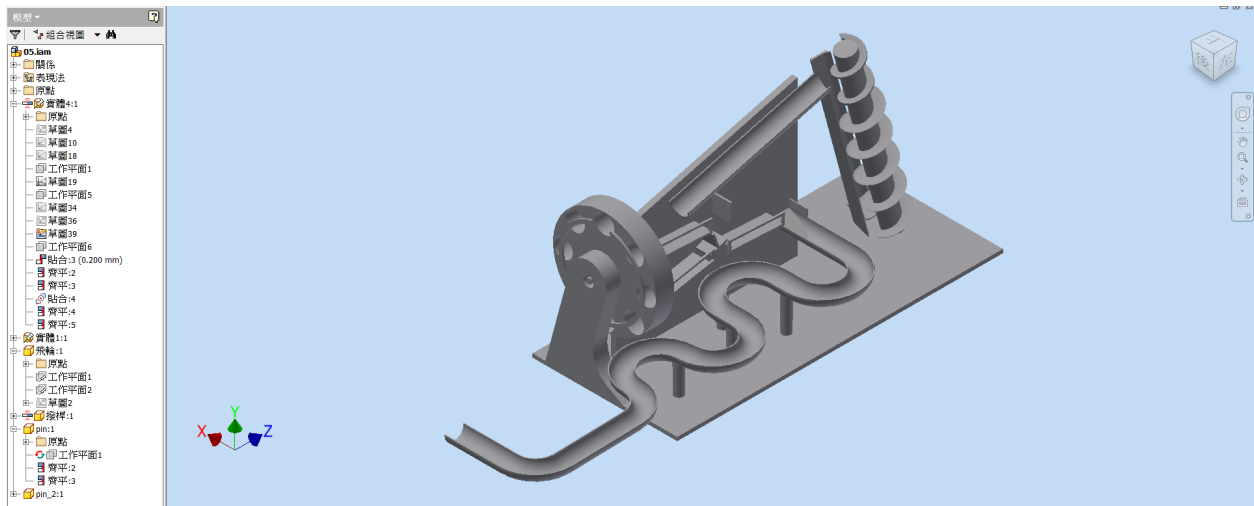

Figure 2.3: Screw-and-Flywheel

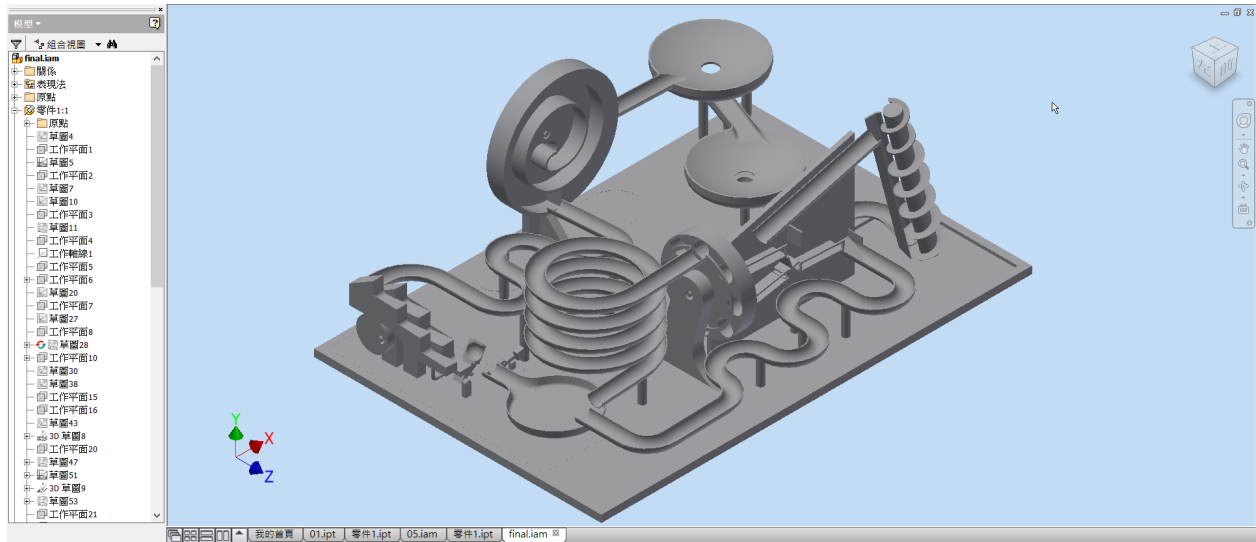

Figure 2.4: Assembly

2.3 V-rep

V-rep provides a unified framework combining many powerful internal and external libraries that are often useful for robotics simulations. This includes dynamic simulation engines, forward/inverse kinematics tools, collision detection libraries, vision sensor simulations, path planning, GUI development tools, and built-in models of many common robots.

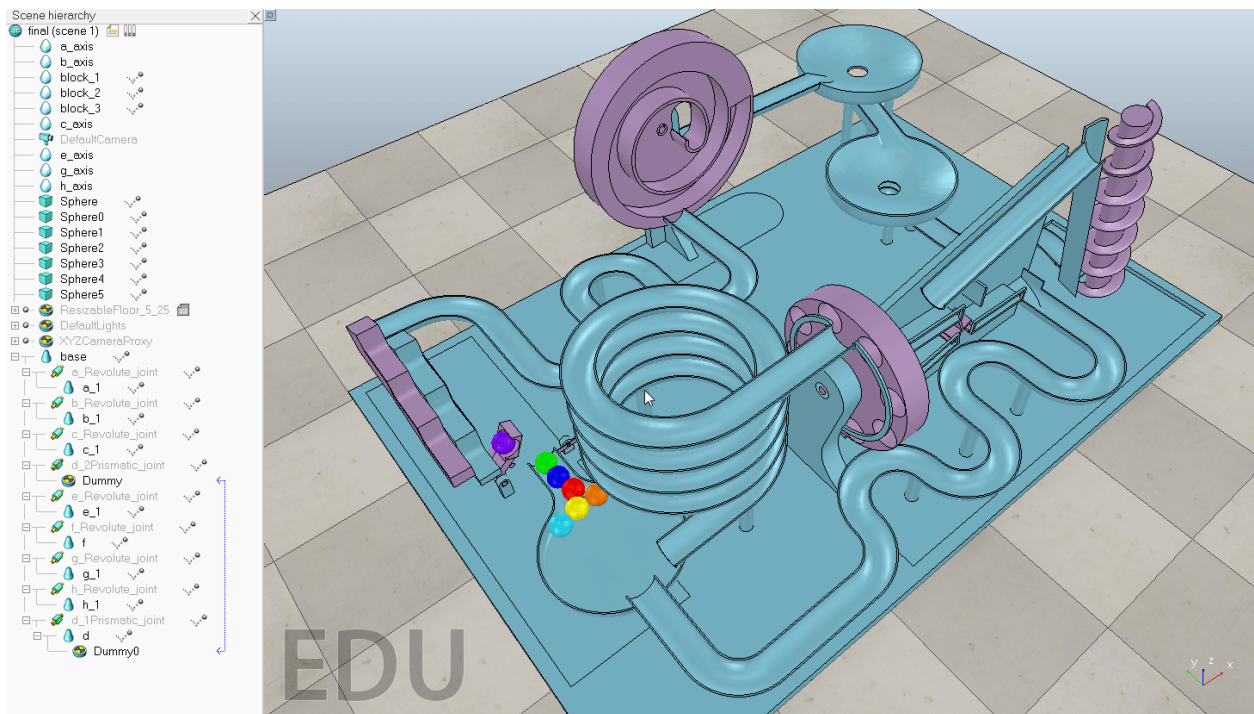

Figure 2.5: Simulation

Chapter 3 Design Introduction

介紹

3.1 Introduction

The four mechanism:

- 1.Lift: Use the motor to drive the eccentric wheel to make the stairs lifting movement.
- 2.Vortex rotating disk: The motor rotates the disk to rise the ball.
- 3.Screw: The motor drives the screw to do oblique upward motion.
- 4.Flywheel: Use the motor to drive the flywheel to make a rotary motion to raise the ball.

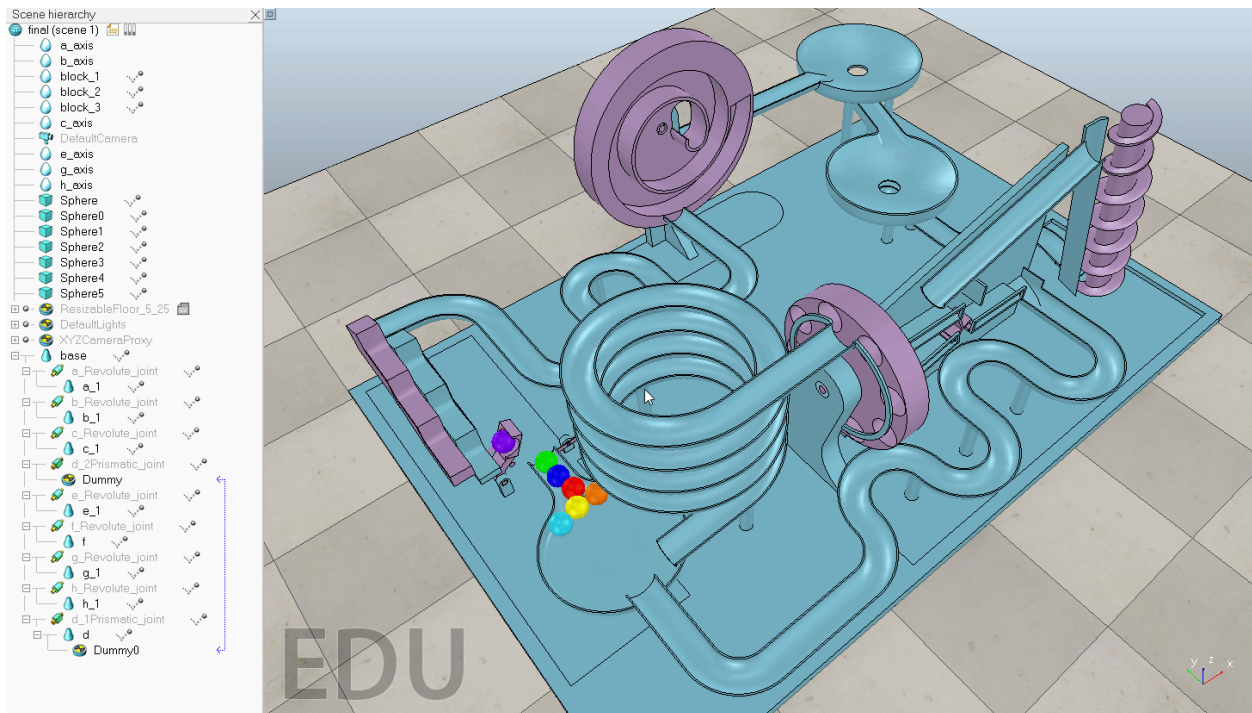

Figure 3.1: Simulation

Chapter 4 Process

過程

4.1 Process

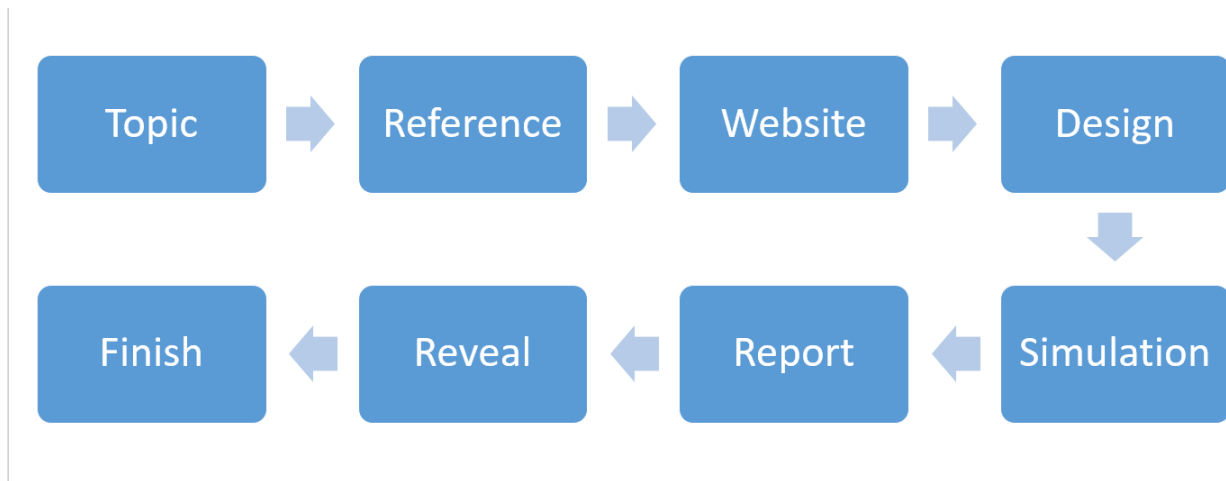

Figure 4.1: Process

Topic: Selected the marble machine system among many topics

Reference: Refer to the video on the web

Website: Edit the final project website

Design: Design and coordinate the mechanism

Simulation: Use V-rep to simulate and move the ball in the track

Report: Make independent study

Reveal: Inform the focus and assignments

Finish: Report completed

Chapter 5 Issue & Solution

Q&A

5.1 Design

Q: Putting the mechanism to the V- rep is easy to interfere when simulating. And, the ball is easy to get stuck in one place in the process.

A: Increase the slope or height of the track

5.2 V-rep

Q: Components cannot be separated

A: There must be a gap between the part and the part, and put them together to be one part.

Q: Turn on body is responsible, the components cannot operate on the normal track, it will flutter.

A: Because the interval between the solid and the solid cannot be 0, there must be gap.

Q: Turn on body is responsible for the track, the simulation will be very lag.

A: Turn it to collide with the ball.

5.3 Report

Q: "Pandoc" Path not found

A: Need to set "path2" and start "path2" in "start.bat"

Q: "LaTeX" Modify name can't skip a line

A: Use "for" loop to compile it

Q: The teacher's name can't be displayed in pdf

A: In "advisor_zh:", skip a line, add "-" and space to write

Q: Can't transfer pdf in "Leo"

A: Excute to specified path

Q: Unbale to update catalog

A: Modify the catalog name under "button Report pdf"

Q: Images can't be displayed

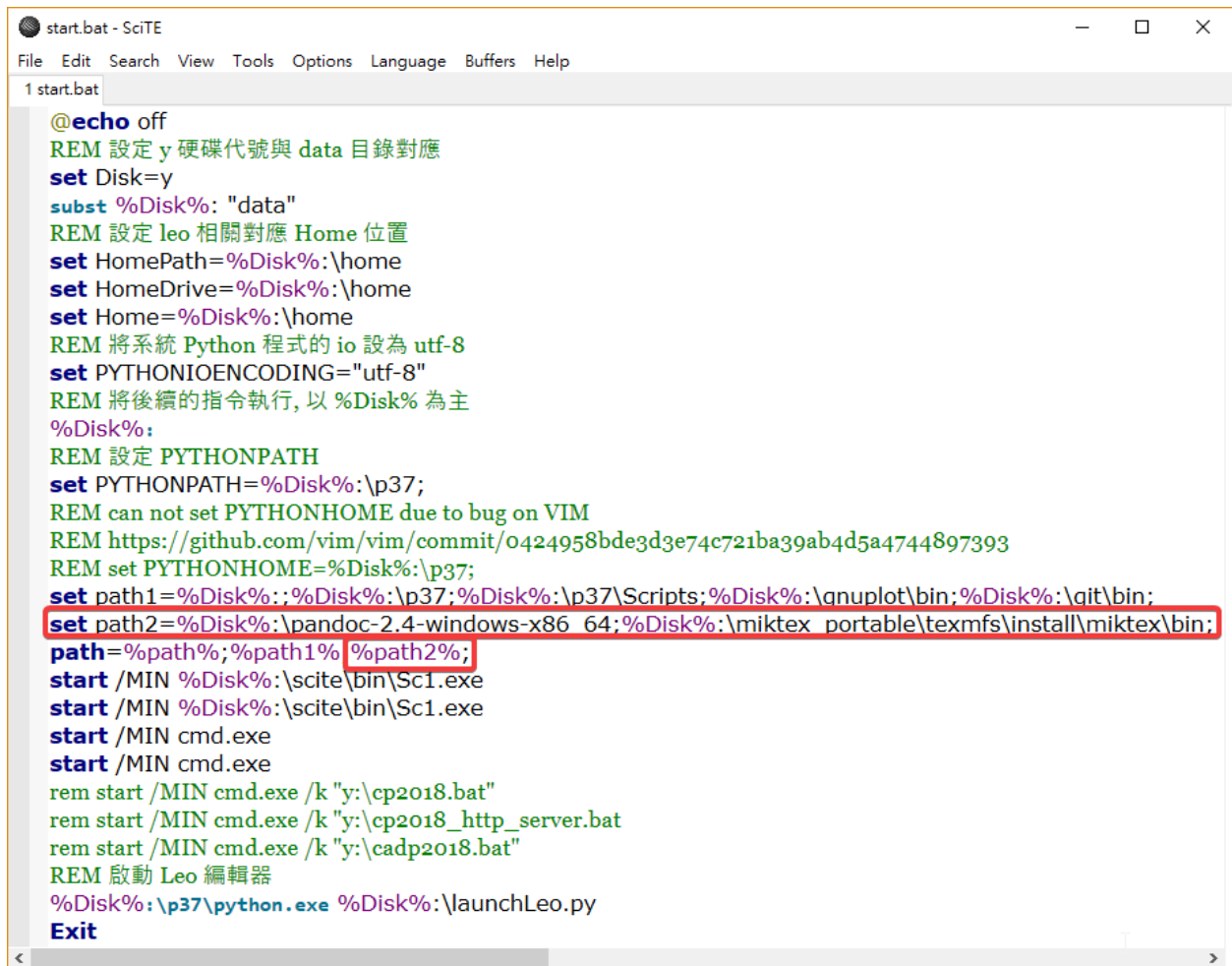

```
start.bat - SciTE
File Edit Search View Tools Options Language Buffers Help
1 start.bat
@echo off
REM 設定 y 硬碟代號與 data 目錄對應
set Disk=y
subst %Disk%: "data"
REM 設定 leo 相關對應 Home 位置
set HomePath=%Disk%:\home
set HomeDrive=%Disk%:\home
set Home=%Disk%:\home
REM 將系統 Python 程式的 io 設為 utf-8
set PYTHONIOENCODING="utf-8"
REM 將後續的指令執行, 以 %Disk% 為主
%Disk%:
REM 設定 PYTHONPATH
set PYTHONPATH=%Disk%:\p37;
REM can not set PYTHONHOME due to bug on VIM
REM https://github.com/vim/vim/commit/0424958bde3d3e74c721ba39ab4d5a4744897393
REM set PYTHONHOME=%Disk%:\p37;
set path1=%Disk%:;%Disk%:\p37;%Disk%:\p37\Scripts;%Disk%:\qnuplot\bin;%Disk%:\git\bin;
set path2=%Disk%:\pandoc-2.4-windows-x86_64;%Disk%:\miktex_portable\texmfs\install\miktex\bin;
path=%path%;%path1% %path2%;
start /MIN %Disk%:\scite\bin\Sc1.exe
start /MIN %Disk%:\scite\bin\Sc1.exe
start /MIN cmd.exe
start /MIN cmd.exe
rem start /MIN cmd.exe /k "y:\cp2018.bat"
rem start /MIN cmd.exe /k "y:\cp2018_http_server.bat"
rem start /MIN cmd.exe /k "y:\cadp2018.bat"
REM 啟動 Leo 編輯器
%Disk%:\p37\python.exe %Disk%:\launchLeo.py
Exit
```

Figure 5.1: Start.bat

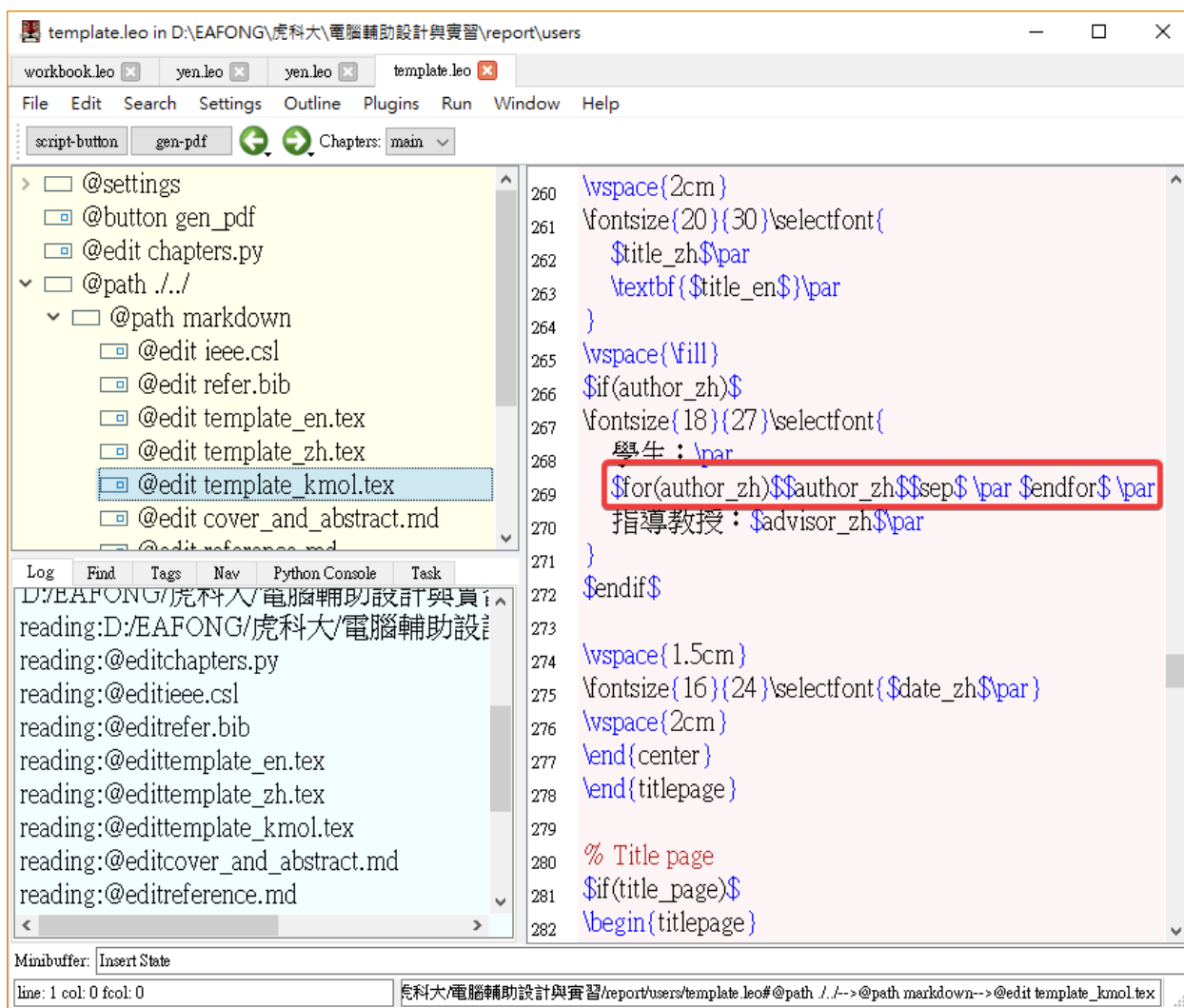

Figure 5.2: For loop

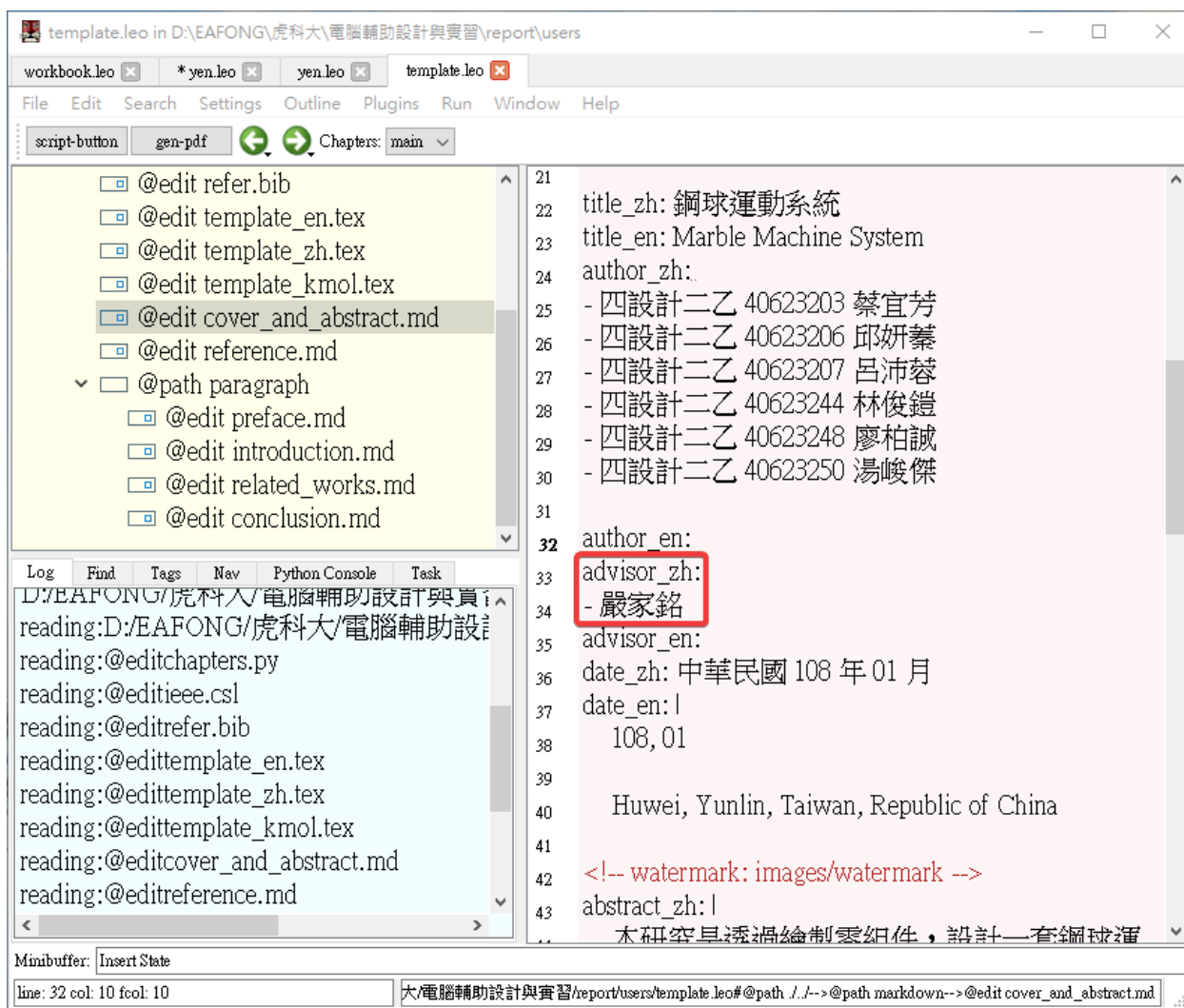

Figure 5.3: Advisor

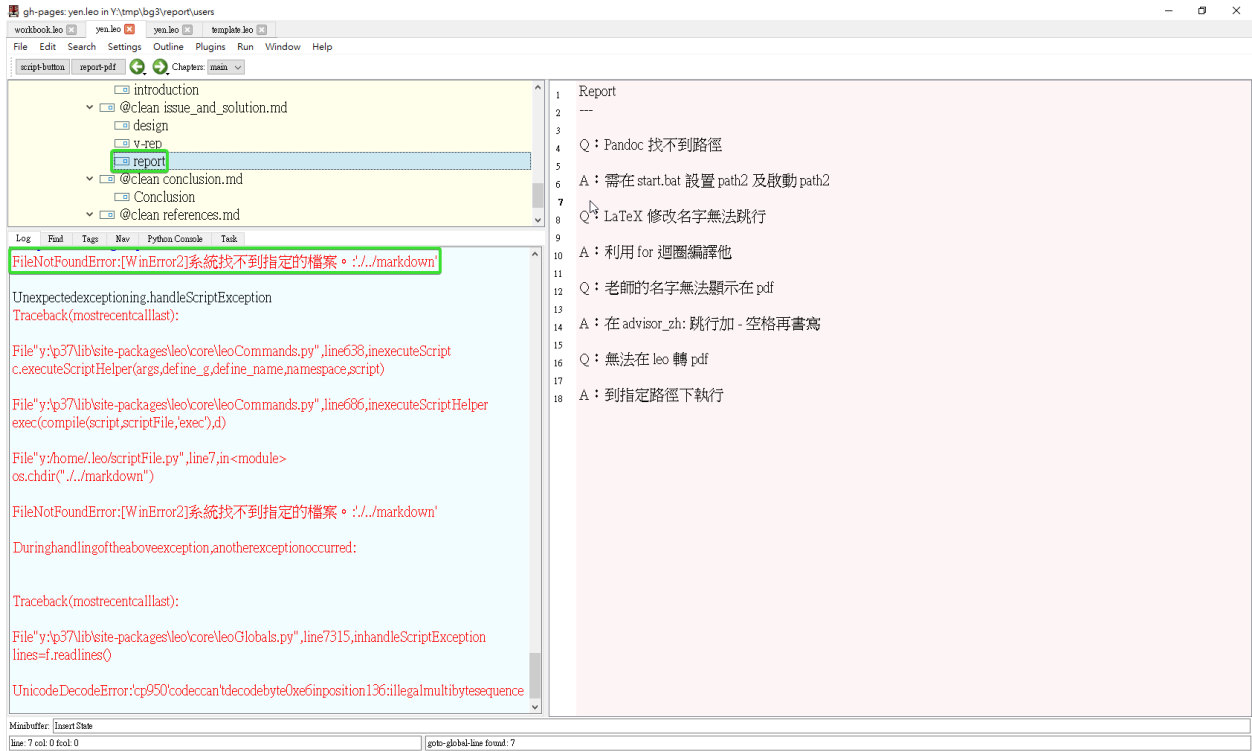

Figure 5.4: transform-mistake

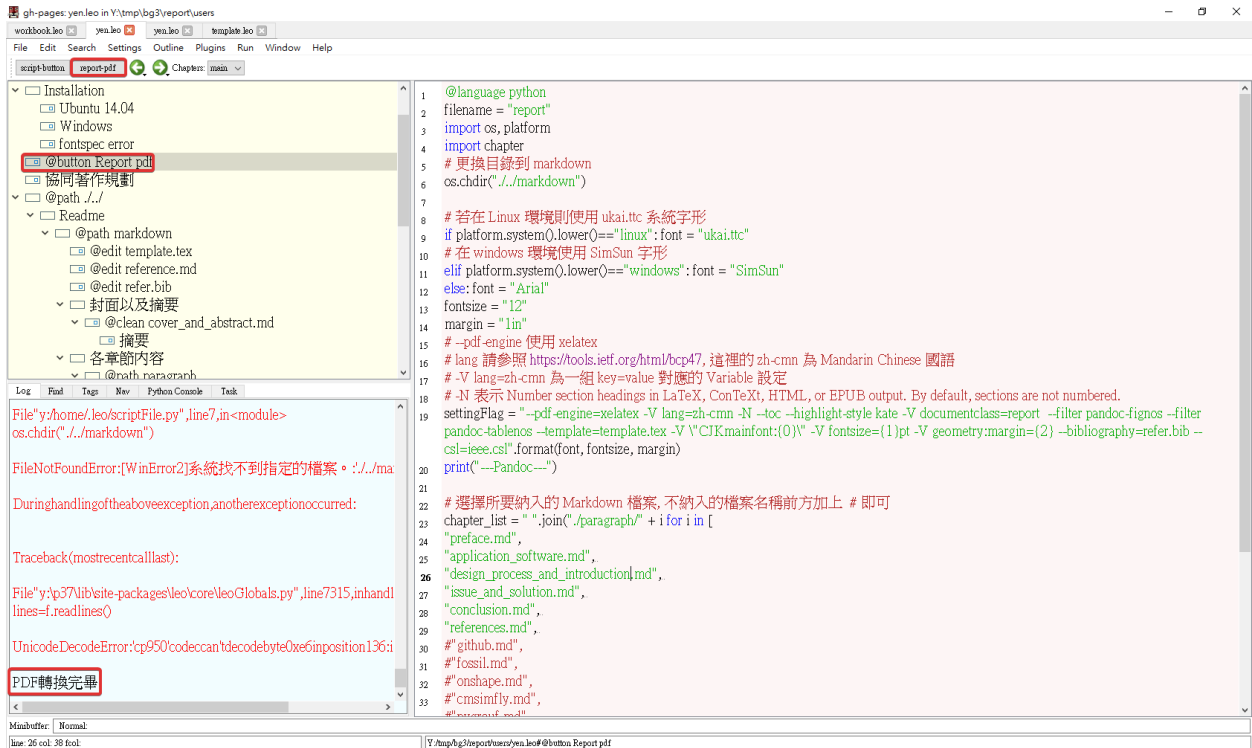

Figure 5.5: transform-correct

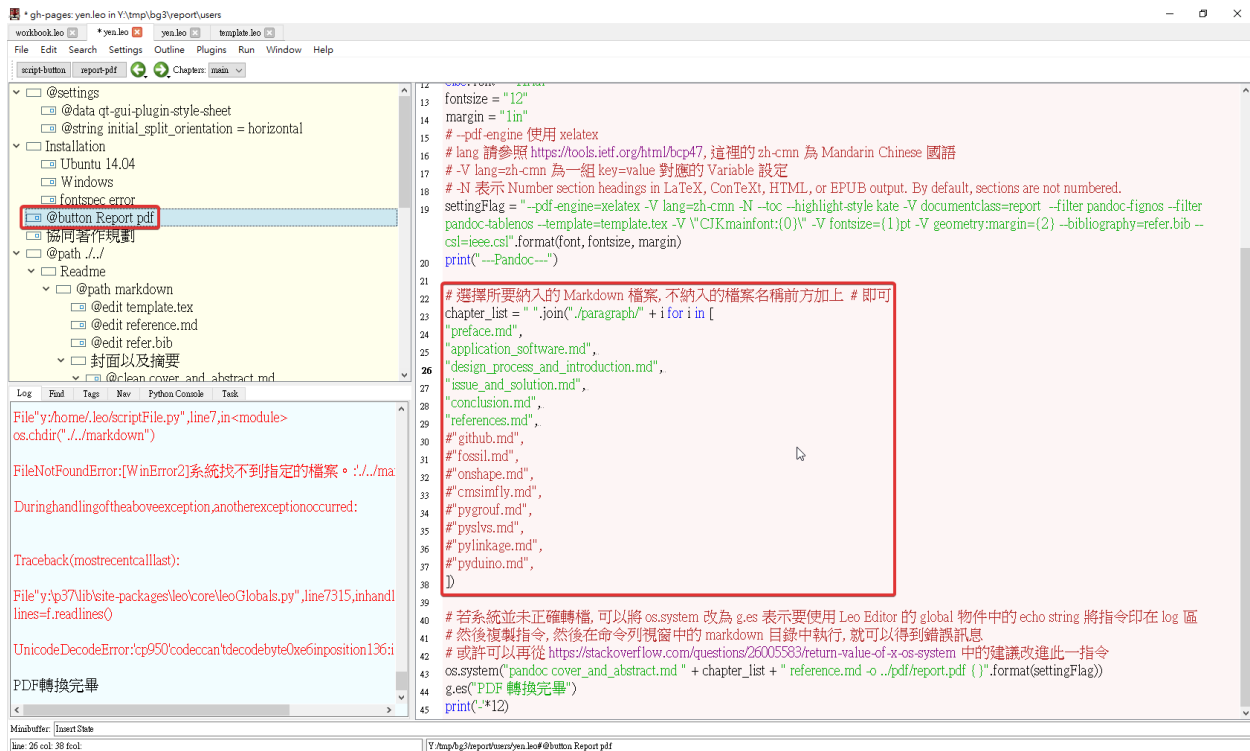

Figure 5.6: modify-chapters

A: Path is wrong. Excute under “images”

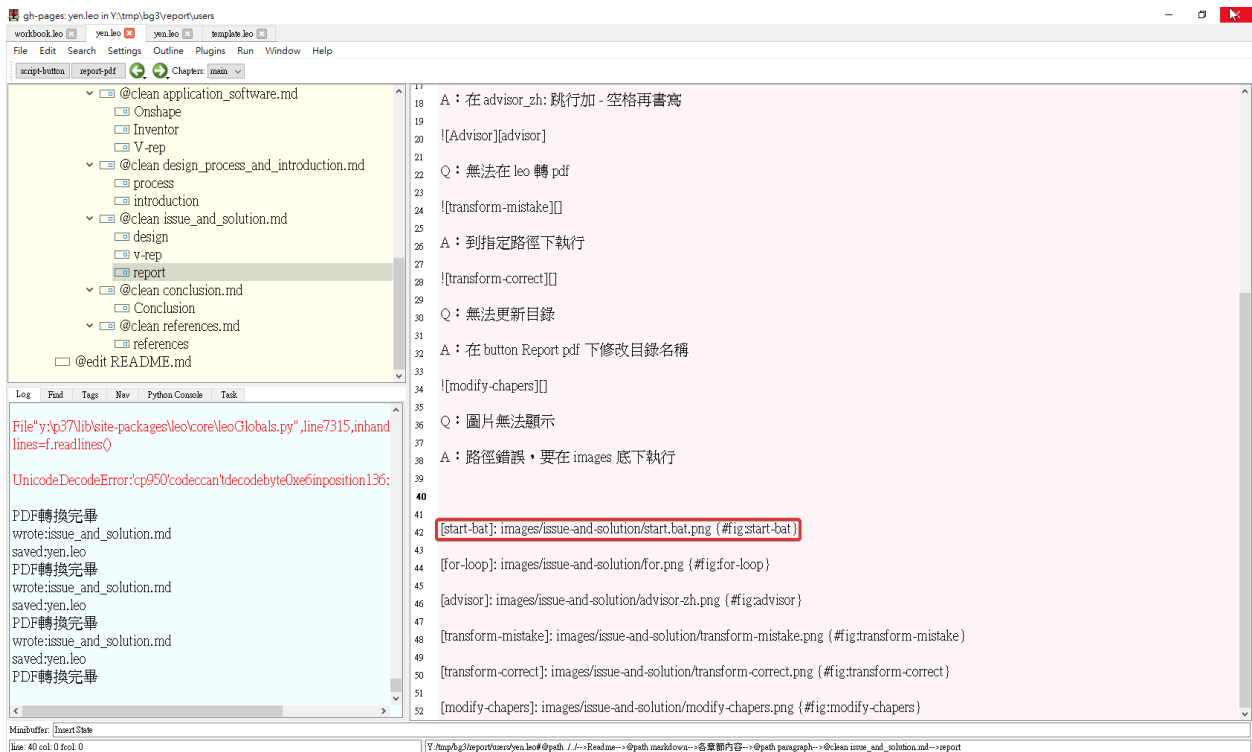

Figure 5.7: image

Chapter 6 Assignments

工作分配

6.1 Assignments

40623203 蔡宜芳: Onshape Interface and Geometry, Website, PDF

40623206 邱妍蓁: Onshape Drawing

40623207 呂沛蓉: Onshape Sheet Metal

40623244 林俊鎧: Design, Translation, inform

40623248 廖柏誠: Onshape Assembled, Design, V-rep

40623250 湯峻傑: Onshape Constraint and Feature, Design

Chapter 7 Conclusion

結論

7.1 Conclusion

We suffer a lot of setbacks in the process at this time, such as assembly interference. It cause the mechanism not to operate smoothly during the simulation and PDF has been unable to solve the problem. With the help of teacher and seniors, we solved our long- standing problems successfully. There have also been differences in opinions among members. After many intense discussions, make everyone know each otther's ideas, unify everyone's opinion and assign appropriate task to each other so that to complete the final project efficiently.

Chapter 8 References

Marble Machine - Triple Gears Lift (Three Blocks Marble Race)

How to make spiral Marble Machine - cardboard toy)

Stairs lifter (2nd test)

How to Make BIG Marble Run Machine from Cardboard

Onshape

Inventor

V-rep