

## Week 4 Homework:

Let's put our newfound knowledge on Limits to practice:

1. Add a Limit to the vice so that the Jaw will not interfere with the Base either when the vise is fully closed or fully open. Which Mate Feature should the Limit be applied to? The Vise should stop at the limits like this:

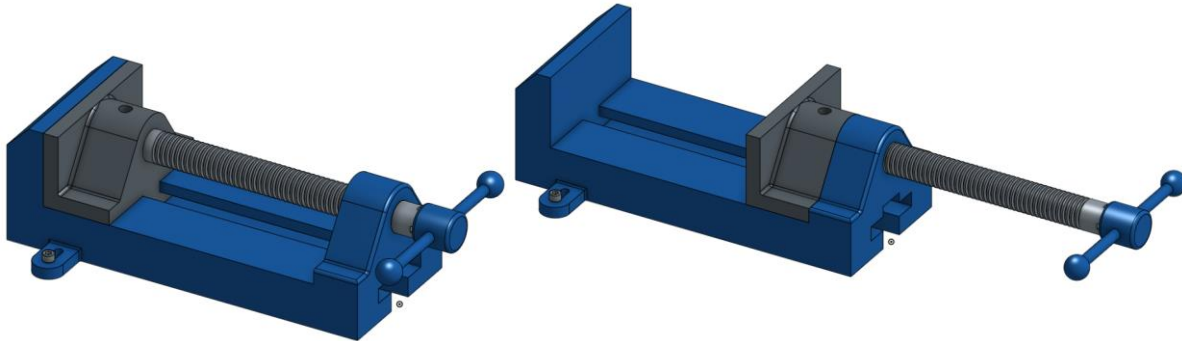

Here is an important dimension to determine the limits:

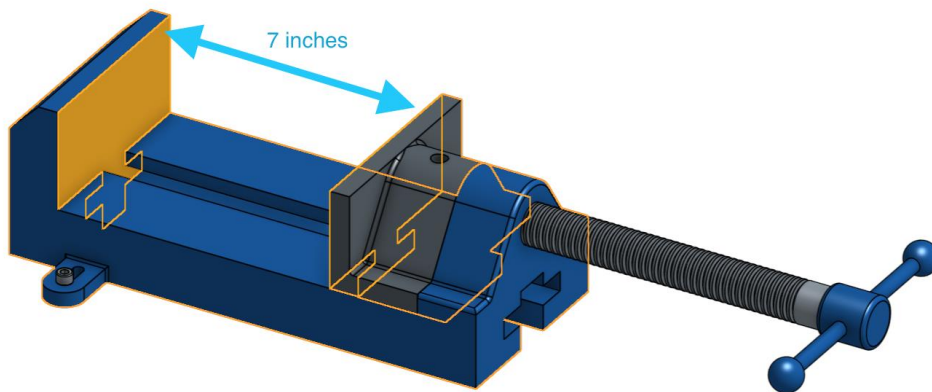

2. Assemble the following sets of hardware (CAD model found [HERE](#)):
  - a. Socket Head Cap Screw with Washers & Nuts
  - b. Flat Head Socket Cap Screw with Washer & Nut
  - c. Pan Head Machine Screw with Washers & Nuts
  - d. Slotted Spring Pin (Flush with bottom of Plate)
  - e. Shoulder Screw with Spacer, Washer & Nut
  - f. Keyed Shaft with Gear and Retaining Ring (Shaft should rotate with key & gear)
  - g. U-Bolt with Nuts (Group the U Bolt & Hardware)
- Note on grouping:
  - i. The nylon lock Nuts consists of two parts (the nylon and the nut), but in real life they are inseparable, so they should be grouped prior to mating.

- ii. The U-Bolt comes with it's own hardware, so it, too, should be grouped prior to assembly.

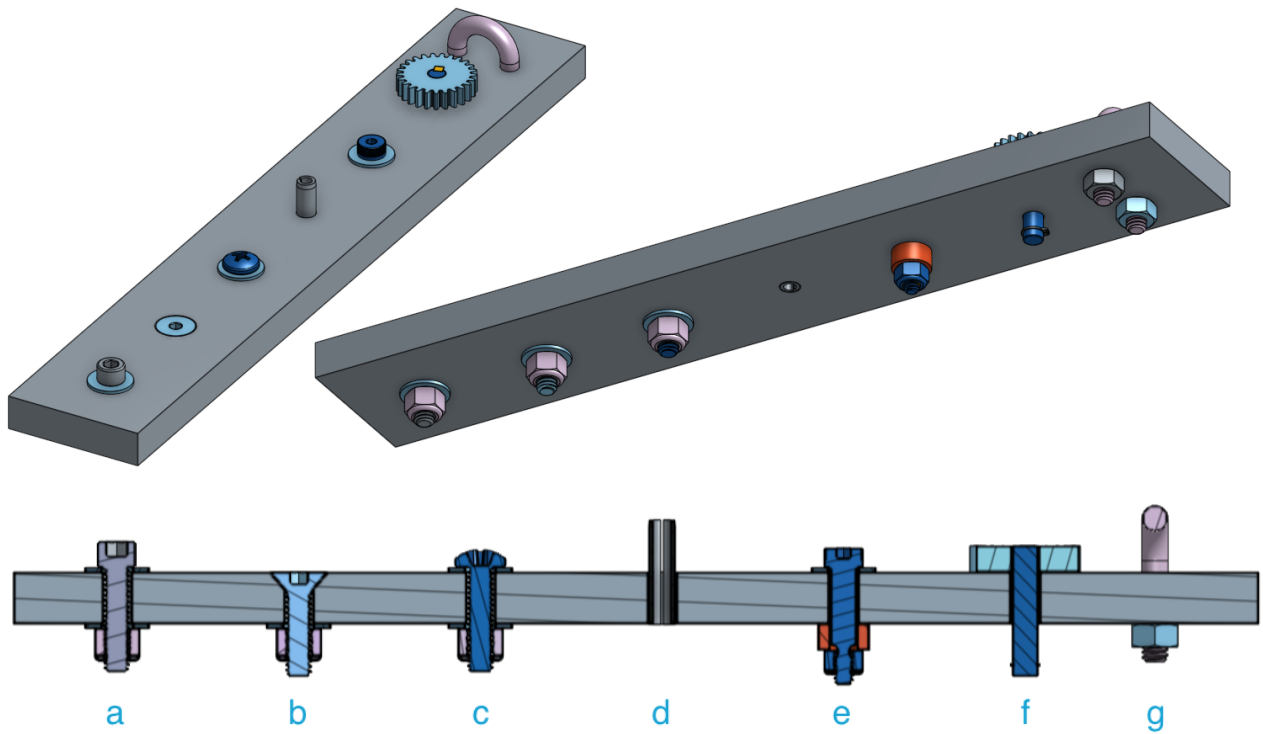

- 3. Finally, add limits to the gear shaft from #2f above so there is no interference with the plate. The total distance the shaft can move is 0.375".

